

Dimensions

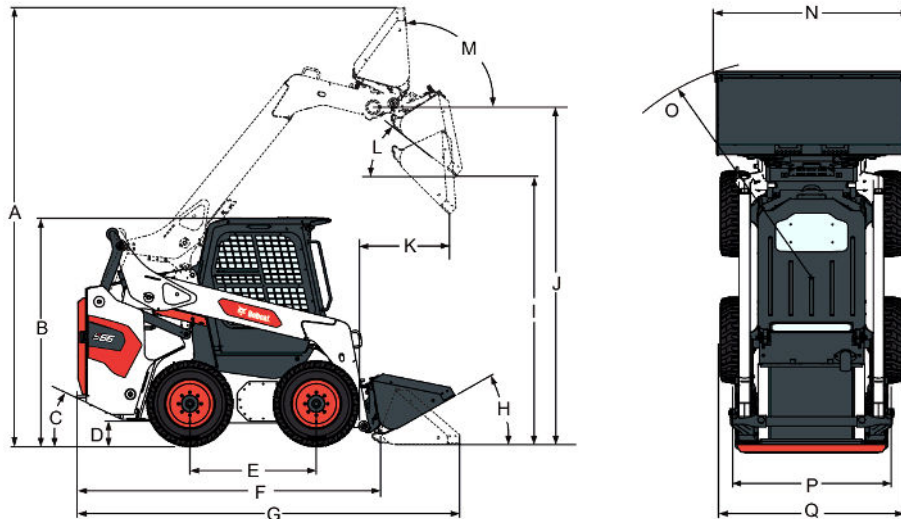

(A) Operating height	3909.6 mm
(B) Height with operator cab	2044.7 mm
(C) Angle of departure	25.0°
(D) Ground clearance	213.7 mm
(E) Wheelbase	1133.3 mm
(F) Length without attachment	2717.8 mm
(G) Length with standard bucket	3427.0 mm
(H) Rollback at ground position	30.0°
(I) Dump height with standard bucket	2395.8 mm
(J) Height to bucket hinge pin	3048.0 mm
(K) Dump reach at maximum height	803.1 mm
(L) Dump angle at maximum height	37.0°
(M) Rollback fully raised at maximum height	94.0°
(N) Width over standard bucket	1727.2 mm
(O) Turning radius with standard bucket	2033.4 mm
(P) Track, standard tyres	1406.6 mm
(Q) Width over standard tyres	1641.5 mm

Performance

Tipping load (ISO 14397-1)	2359 kg
Rated operating capacity (ISO 14397-1)	1184 kg
Lift breakout force	2200 daN
Tilt breakout force	2440 daN
Push Force	2758 daN

Cycle Times

Raise lift arms	3.8 s
Lower lift arms	2.5 s
Bucket rollback	1.7 s
Bucket dump	2.3 s

Weights

Operating weight	3271 kg
Shipping weight	2939 kg

Engine

Make / Model	Bobcat 2.4L, 97/68 EC Stage V
Fuel	Diesel
Cooling	Liquid
Power at 2600 RPM	54.5 kW
Torque at 1425 RPM (SAE J1995 Gross)	266.3 Nm
Number of cylinders	4
Displacement	2400 cm ³
Bore	90.0 mm
Stroke	94.0 mm
Lubrication	Ger pump pressure with filter
Crankcase ventilation	Closed breathing
Air filter	Dry replaceable cartridge with safety element
Ignition	Diesel-compression

Electrical

Alternator	Belt driven — 90 A — open frame with internal regulator
Battery	12 V — 600 A cold cranking at -18°C — 115 min reserve capacity at 25 A
Starter	12 V — gear reduction type — 2.7 kW

Hydraulic System

Pump type	Engine driven, gear type
Pump capacity	66.50 L/min
Pump capacity (with high flow option)	101.80 L/min
System relief at quick couplers	23.8-24.5 MPa
Control valve	Three-spool, open-centre type with float detent on lift and electrically controlled auxiliary spool
Hydraulic filter	Full-flow replaceable — 10 µm synthetic media element
Fluid lines	SAE standard tubelines, hoses, and fittings

Hydraulic Cylinders

Lift cylinder (2)	Double-acting
Lift cylinder bore	69.9 mm
Lift cylinder rod	41.4 mm
Lift cylinder stroke	540.0 mm
Tilt cylinder (2)	Double-acting with cushioning feature on dump and rollback
Tilt cylinder bore	69.9 mm
Tilt cylinder rod	38.1 mm
Tilt cylinder stroke	330.7 mm

Drive System

Transmission	Infinitely variable tandem hydrostatic piston pumps, driving two fully reversing hydrostatic motors
Final drive chains	Pre-stressed #80 HSOC endless roller chain (no master link) and sprockets in sealed chaincase with oil lubrication. (Chains do not require periodic adjustments.) Two chains per side with no idler sprocket.
Main drive	Fully hydrostatic; four-wheel drive
Axle size	50.3 mm, heat treated. Axle tubes welded to chaincase. Labyrinth axle seal protection.
Wheel bolts	Eight 9/16–inch wheel bolts fixed to axle hubs

Traction

Standard tyres	10 x 16.5, 10–ply, Bobcat heavy duty
Heavy duty tyres	10 x 16.5, 10–ply, Bobcat heavy duty, offset rims
Severe duty tyres	10 x 16.5, 10–ply, Bobcat severe duty
Poly fill tyres	10 x 16.5, 10–ply, Bobcat severe duty, poly filled
Solid flex tyres (option)	12 x 16.5, Bobcat solid flex
Float tyres	31 x 12-16.5, 10–ply, Bobcat superflotation, offset rims
Max. travel speed (low range)	11.8 km/h
Max. travel speed (high range - option)	17.3 km/h
Gradeability	11.0°

Fluid Capacities

Chaincase reservoir	32.20 L
Cooling system	11.40 L
Cooling system with heater	11.70 L
Engine oil with filter	9.70 L
Fuel tank	93.70 L
Hydraulic reservoir	7.57 L
Hydraulic / Hydrostatic system	36.00 L

Fluid Specifications

Engine coolant	Propylene glycol/water mix (53% - 47%) with freeze protection to -37°C 5 L can - 6904844A, 25 L container - 6904844B, 209 L drum - 6904844C, 1000 L tank - 6904844D
Engine oil	Oil must meet API Service Classification of CD, CE, CF4, CG4, or better. Recommended SAE viscosity number for anticipated temperature range.

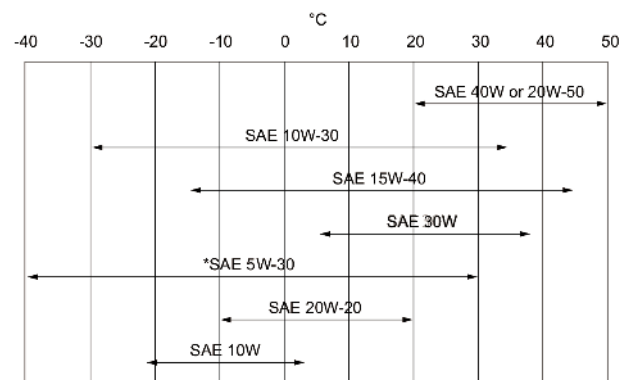

Hydraulic fluid	<p>* Can be used only when available with appropriate diesel rating. For synthetic oil use the recommendation from the oil manufacturer.</p> <p>Bobcat Superior SH, 5 L can - 6904842A, 25 L container - 6904842B, 209 L drum - 6904842C, 1000 L tank - 6904842D</p> <p>Bobcat Bio Hydraulic, 5 L can - 6904843A, 25 L container - 6904843B, 209 L drum - 6904843C, 1000 L tank - 6904843D</p> <p>Motor oil is not an acceptable alternative fluid.</p>
-----------------	---

Controls

Engine Starting	Hand lever throttle Key-type starter switch and shutdown or optional keyless start. Glow plugs automatically activated by Standard or Deluxe instrument panel.
Front auxiliary (standard) Rear auxiliary (optional) Loader hydraulics tilt and lift Service brake	Electrical switch on right-hand steering lever Electrical switch on left-hand steering lever Selectable Joystick Controls (SJC) or separate foot pedals Two independent hydrostatic systems controlled by two hand-operated steering levers
Secondary brake Parking brake	One of the hydrostatic transmissions Mechanical disc, hand-operated rocker switch on dash panel
Parking brake, two-speed option	Spring applied, pressure released multi-disk brake activated by rocker switch
Vehicle steering	Direction and speed controlled by Selectable Joystick Controls (SJC) or two hand levers
Auxiliary pressure release	Pressure is relieved through the coupler block. Push in and hold for 5 s.

Instrumentation

The following loader functions are monitored by a combination of gauges and warning lights in the operator's line of sight. The system alerts the operator of monitored loader malfunctions by way of audible alarm and visual warning lights.

Standard Instrument Panel

- Gauges
 - Engine coolant temperature
 - Fuel
- Indicators
 - Bobcat Interlock Control System
 - Engine preheat
 - Two speed
 - Turn signals
- Warning lights
 - Engine coolant temperature
 - Fuel level
 - General warning
 - Seat belt
 - Seatbar down
 - Engine malfunction
 - Hydraulic system malfunction
 - Lift and tilt valve, hydraulics lock-out
 - Parking brake
 - Hydraulic oil temperature
 - Engine oil pressure
 - Hydraulic oil pressure
- Buttons
 - Work lights and road lights
 - High flow auxiliary hydraulics
 - Auxiliary hydraulics
 - Information (Hour meter, Engine RPM, Battery voltage, Service codes, Service reminder, Maintenance clock)
 - Traction lock override
 - Press to operate loader
- Rocker switch
 - Parking brake
- Alarm
 - Beep when error, warning or shutdown condition exists

Deluxe Instrument Panel

Same gauges, warning lights and other features as Standard Instrument Panel, plus:

- Gauges
 - Engine oil pressure / temperature
 - Hydrostatic charge pressure
 - Hydraulic oil temperature
 - Battery

- Additional features
 - Keyless start with password capability
 - Digital clock
 - User name and hourmeter
 - Attachments control information
 - Current job hours
 - High Flow lockouts
 - Multi-language display
 - Help screens
 - Diagnostic capability
 - Engine/hydraulic systems shutdown function
 - Password lockout
- Icons
 - Active warnings
 - Vitals (Engine speed, Oil Pressure, Temperature, System voltage, Hydraulic charge pressure, Oil temperature)
 - Service
 - Main screen
 - Attachments
 - Security
 - Display
- Buttons
 - Left scroll
 - Enter
 - Right scroll

Serviceability

Access is available to the following through the rear door/tailgate and rear screen:

- Air cleaner
- Alternator
- Battery
- Cooling radiators
- Engine oil and fuel filters
- Engine oil drain and dipstick
- Hydraulic oil fill
- Starter

Axle hubs provide protection for the axle seals

Bob-Tach™ pivots have replaceable wear bushings

Easy access to all grease points

Rod end of the tilt cylinder has a replaceable bushing

Tailgate has an optional lock for vandal-proofing

Tailgate is equipped with door-stop to hold door open while servicing

Tip-up operator cab gives access to certain hydraulic system components

Standard Features

- 10 x 16.5, 10-ply, Heavy duty tyres
- 3 Point Seat belt
- 5" Deluxe Instrumentation (Radio Ready)
- Adjustable suspension seat
- Auxiliary hydraulics: variable flow/maximum flow
- Backup Alarm
- Bobcat Interlock Control System (BICS)
- Bob-Tach™ Attachment System

- Deluxe pressurized cab with HVAC
- Dual Direction Bucket Positioning (including ON/OFF switch)
- Engine/hydraulics system shutdown
- High flow hydraulics
- Horn
- Key start
- LED Working Lights front and rear
- Lift arm support
- Manual
- Parking brake
- Seat bar
- Selectable Joystick Controls (SJC)
- Spark arrestor muffler
- Two speed travel
- Warranty: 24 months or 2000 hours (whichever occurs first)
- Machine IQ (telematic)

Options

- Factory Options
 - 10 x 16.5, 10-ply, Heavy duty tyres, offset rims
 - 10 x 16.5, 10-ply, Severe duty tyres
 - 12 x 16.5, Solid flex tyres
 - 31 x 12-16.5, 10-ply, Superflotation tyres , offset rims
 - 7" Touch Display (Integrated Bluetooth, Hands Free Calling, Radio, Reversing Camera)
 - Auto HVAC
 - Auto Ride Control
 - Beacon
 - Clear View Cab
 - Heated Cloth Air ride seat with 3 point seat belt
 - Manual Hand and Foot Controls
 - Power Bob-Tach™
 - Radio
 - Reversible Fan
 - Reversing Camera
 - Strobe

- Dealer Installed Options
 - Cab enclosure kit
 - Special applications front door kit
 - 200 lbs (74.4 kg) counterweight kit
 - Front axle counterweight kit
 - Deluxe instrument panel
 - Replacement Bob-Tach™
 - Fresh air heater kit
 - Front door kit
 - Door sensor kit
 - Plumbing kit for fresh air heater
 - Back up alarm kit
 - FOPS kit **
 - Single-point lift kit
 - Power Bob-Tach™ kit
 - Cab enclosure kit
 - 7-pin attachment control
 - Four-point lift kit
 - Rear auxiliary hydraulic kit
 - Engine block heater kit
 - Road kit
 - Bucket positioning kit
 - Keyless kit
 - Rear window wiper kit
 - 14-pin attachment control kit
 - 4-Way flasher kit
 - 80 mm Suspension seat kit
 - Cup holder kit
 - Headlight guard kit
 - Muffler guard kit
 - Tail light guard kit

Attachments

- Angle Brooms
- Auger Accessories
- Augers
- Backhoes
- Bale Forks
- Box Blades
- Breaker Accessories
- Breakers
- Brushcat™ Rotary Cutters
- Brush Saws
- Combination Buckets
- Concrete Mixers
- Concrete Pumps
- Construction / Industrial Buckets
- Diggers
- Dozer Blades
- Drop Hammers
- Dumping Hoppers
- Fertilizer and Grain Buckets
- Pallet Fork Accessories
- Pallet Forks, Hydraulic
- Planer Accessories
- Planers
- Root Grapples
- Rotary Grinders
- Scarifiers
- Scrapers
- Skeleton Buckets
- Snow & Light Material Buckets
- Snow Blades
- Snow Pushers
- Snow V-Blades
- Sod Layers
- Soil Conditioners
- Spreaders
- Steel Tracks
- Stump Grinders
- Sweepers

GET **A QUOTE**

Simply click **the button** or scan **the QR code** below to access our quote request form.

We will contact you as soon as possible.
Thank you!



REQUEST QUOTE >