

Dimensions

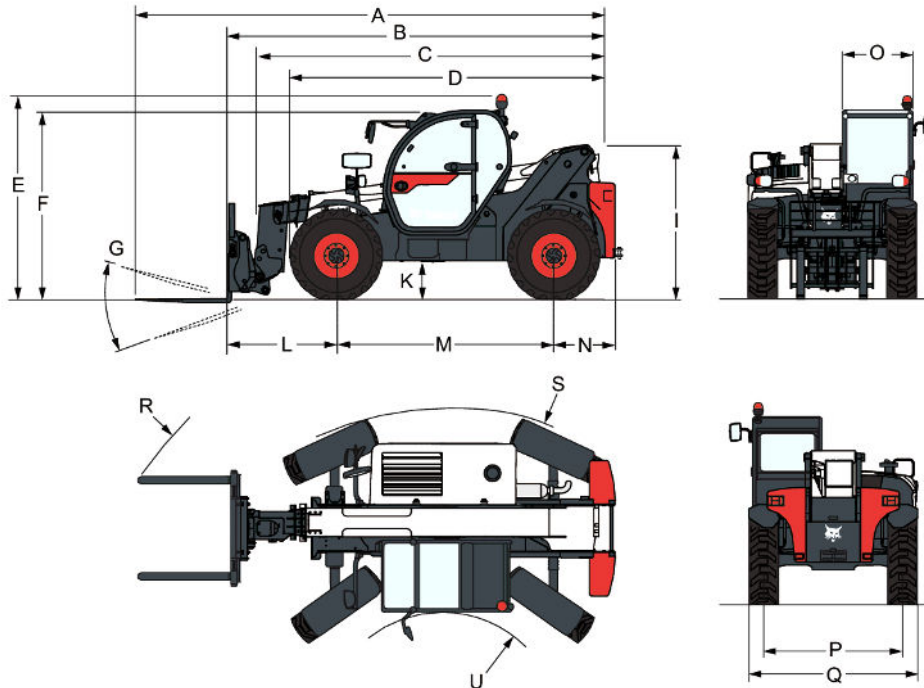
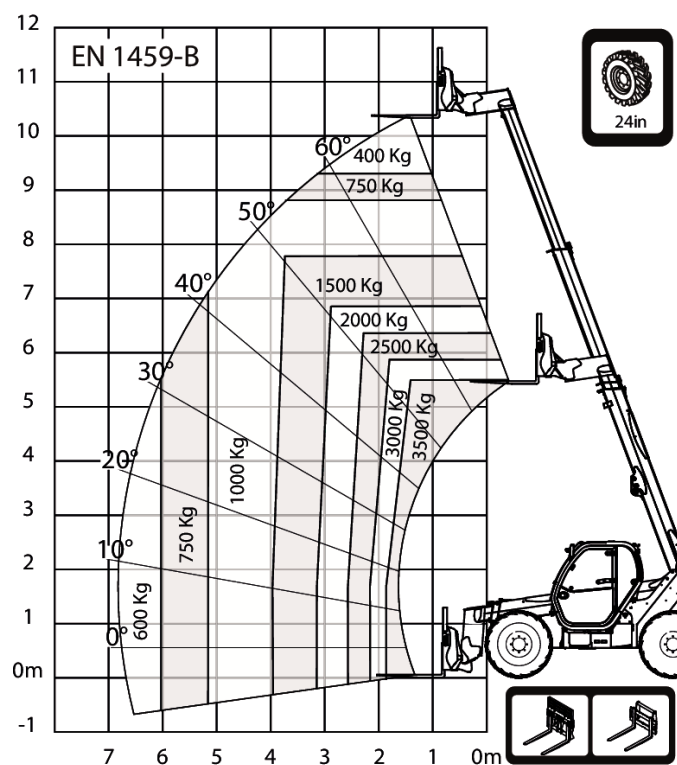
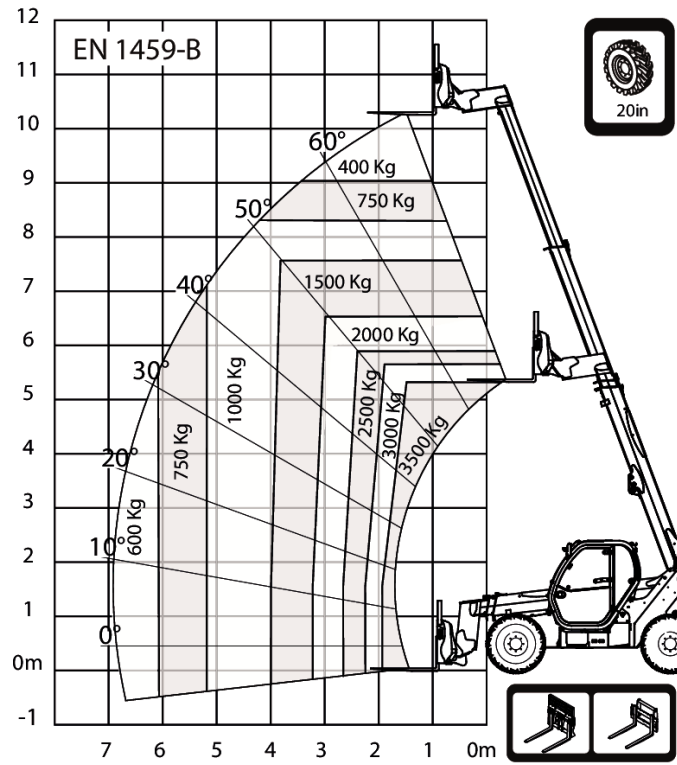
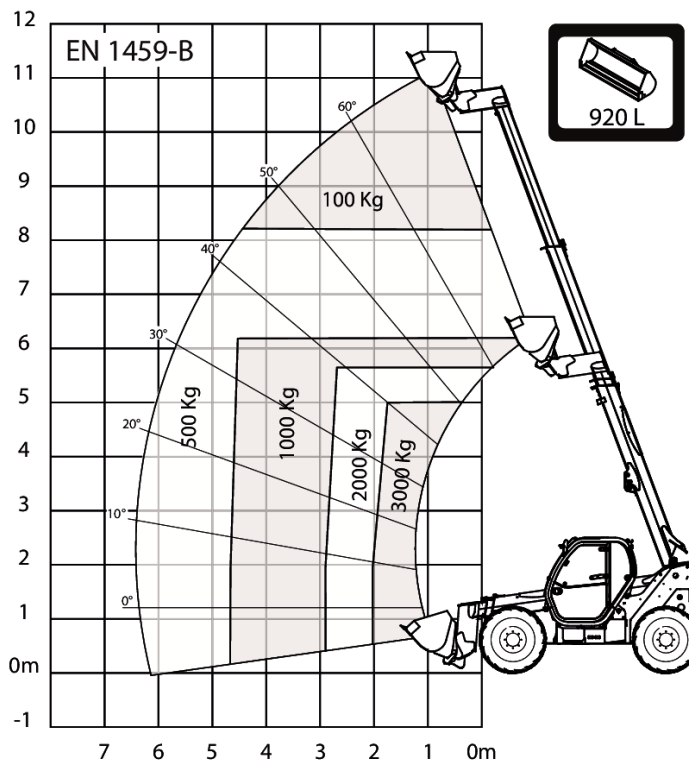
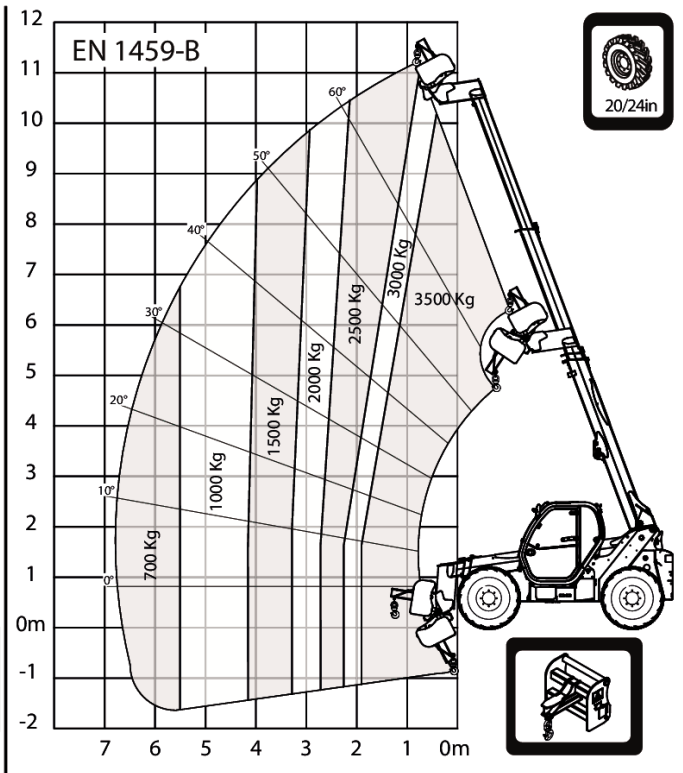
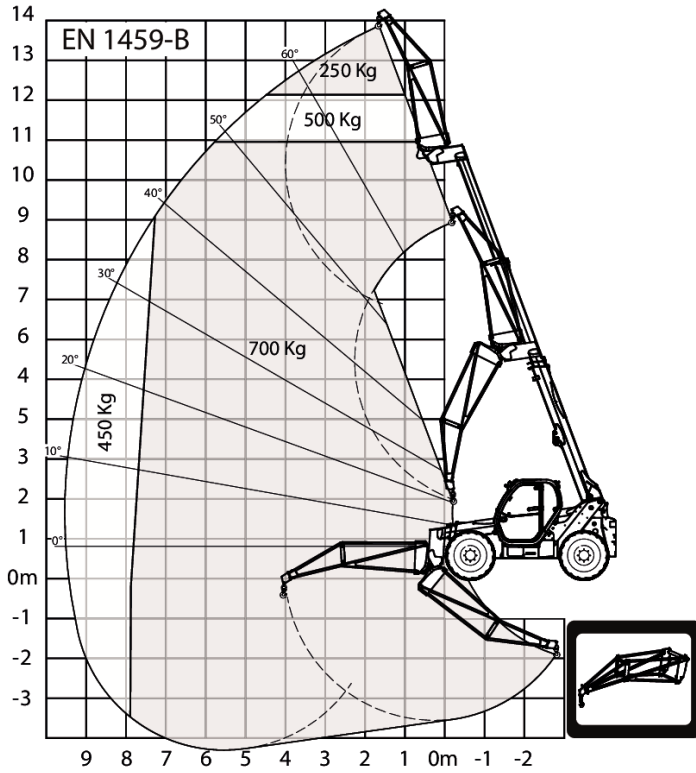

(A) Overall length (to forks tip)	6276.0 mm
(B) Overall length (to forks face)	5071.0 mm
(C) Overall length (to headstock pin)	4936.0 mm
(D) Overall length (to front tyres / Stabilizers (when equipped))	4192.0 mm
(E) Overall height (with rotating beacon)	2584.0 mm
(F) Overall height (with roof wiper)	2430.0 mm
(I) Height back of the machine	1941.0 mm
(K) Ground clearance	415.0 mm
(L) Length - Front axle to forks face	1422.0 mm
(M) Wheelbase	2850.0 mm
(N) Length - Rear axle to machine rear	799.0 mm
(O) Operator cab outside width	930.0 mm
(P) Track width	1862.0 mm
(Q) Width over standard tyres	2264.0 mm
(S) External turning radius (at tyres)	3765.0 mm
(U) Internal turning radius (cab)	1245.0 mm
(R) External turning radius (with forks spaced 1040 mm ext.)	5025.0 mm
(G) Carriage rotation angle	143.0°

Lastdiagram

Lastdiagram

Performance

Tilt Breakout force	7800 daN
Dragstång dragkraft (20-tumsdäck)	5400 daN
Dragstång dragkraft (24-tumsdäck)	4500 daN
Max. gradeability (20" tyres)	33.0°
Max. gradeability (24" tyres)	33.0°
Max. gradeability with rated load (20" tyres)	30.0°
Max. gradeability with rated load (24" tyres)	24.0°
Rated capacity	3500 kg
Capacity (at max. height on tyres)	400 kg
Kapacitet vid max räckvidd (20-tumsdäck)	600 kg
Kapacitet vid max räckvidd (24-tumsdäck)	600 kg
Lyfthöjd (20-tumsdäck)	10290.0 mm
Lyfthöjd (24-tumsdäck)	10375.0 mm
Max räckvidd (20-tumsdäck)	6886.0 mm
Max räckvidd (24-tumsdäck)	6795.0 mm
Reach at max height on tyres (20" tyres)	1480.0 mm
Reach at max height on tyres (24" tyres)	1389.0 mm

Cykeltider

Boom raising	12.5 s
Boom lowering	7.0 s
Boom extension	13.0 s
Boom retraction	7.0 s
Crowding	5.0 s
Dumping	4.5 s

Weights

Olastad vikt (20-tumsdäck)	7080 kg
Unladen operating Weight (20" tyres)	7270 kg
Unlade operating Weight on front axle (20" tyres)	2925 kg
Unladen operating Weight on rear axle (20" tyres)	4345 kg
Olastad vikt (24-tumsdäck)	7180 kg
Unladen operating Weight (24" tyres)	7370 kg
Unlade operating Weight on front axle (24" tyres)	2975 kg
Unladen operating Weight on rear axle (24" tyres)	4395 kg
Max ground Pressure on tyres-hard soil	11.0

Engine

Make / Model	Bobcat D34
Fuel	DIESEL
Cooling	COOLANT
Rated power (ISO 14396)	55.0 kW
Rated speed	2400.0 RPM
Maximum torque at 1400 rpm	360.0 Nm
Number of cylinders	4.0
Displacement	3.41 L
Bore	98.0 mm
Stroke	113.0 mm
Lubrication	Gear pump pressure

Crankshaft Ventilation	Close breathing
Air filter	Dry replaceable cartridge with safety element
Ignition	Diesel compression

Electrical

Alternator	140 A
Battery	110.0
Starter	2.7 kW

Hydraulic System

Pump type	Gear pump with LS valve
Pump capacity	80.00 L/min
Relief valve pressure setting	250.00 bar
Control valve type	Open center with flow sharing & flow compensators technology
Hydraulic filter specs	Full flow filtration
Auxiliary flow front	65.00 L/min

Drive system

Transmission	Hydrostatic with electronic regulation
Main Drive	Hydrostatic motor

Traction

Standard Tyres	405/70-20 16PR TM R4
Max speed - rabbit mode (24" / 20")	24 / 20,5

Optional Tyres

CAMSO 400/80-24 / 20PR TM R4
MICHELIN 400/80-24 162A8 IND TL POWER CL
DUNLOP 405/70R24 168A2 152J MPT SPT9
DUNLOP 405/70R20 168A2 152J MPT SPT9

Brakes

Engine Braking	Hydrostatic
Parking and Emergency brake	Passive brake
Service Brake	Oil immersed discs

Steering

Steering Pump	Priority valve on pump
Steering Mode	2 wheel steering / 4 wheel steering / Crab-steering

Fluid Capacities

Axles front/rear	8,2/9,1
Gear box	0.80 L
Cooling system with heater	14.50 L
Engine oil with filter	12.60 L
Fuel tank	130.00 L
Hydraulic tank	69.00 L
Hydraulic system	121.00 L

Fluid Specifications

Coolant	Ethylen Glycol Mix 50:81
Engine Oil	"ACEA E7/9 API CJ-4 or above Viscosity: -30 to 40 °C : SAE 0W30 -20 to 40°C : SAE 5W30 -15 to 40°C : SAE 10W30"
Fuel	"Diesel fuel low Sulphur - EN 590 : 2013 -ASTM D975C-15 Grade 1D or 2D S15"
Brake Fluid	None. Brakes use hydraulic system pressure
Hydraulic Fluid	MS68
Transmission Oil	ELF SF3 / TOTAL DYNATRANS FR
Grease for hinges and boom gliders	TOTAL MULTIS EP2

Controls

Engine	Electronic engine speed governor
Starting	Key-type starter switch and shutdown.
Front auxiliary	Variable thumbwheel on joystick
Boom raising / lowering	Joystick electronic
Boom extension /retraction	Variable thumbwheel on joystick
Service brake	Pedal-activated wet multi-disk on front axle
Secondary brake	Passive brake
Parking brake	Passive brake
Steering	Proportional hydraulic steering via a conventional steering wheel
Speed range and Forward/reverse drive	Switch for hydrostatic motor and switch on joystick or lever for FNR
Steering modes	Button and screen for selection
Auxiliary pressure release	Standard coupler + pressure release on control valve spool
Eco mode	Eco mode switch
SHS mode	SHS mode switch

Instruments

Instruments

- Gauges
 - Engine RPM
 - Total operating hours
 - Job hours
 - Boom angle
 - Vehicle speed
 - Fuel gauge
 - Engine coolant temperature gauge

- Indicators
 - Front and rear wheel alignment status on screen
 - Headlight full beam
 - Headlight low beam
 - Position lights
 - Left and right turn
 - Trailer turn
 - Parking brake
 - Longitudinal stability level
 - Windscreen wipers
 - Work lights
 - Flashing warning light
 - Hazard warning lights
 - Gear Speed choice
 - Hydraulic function lock
 - Rear fog lights
 - Heater fan
 - Hydraulic fluid over-temperature
 - Engine coolant over-temperature
 - Low oil pressure
 - Battery not charging
 - Longitudinal stability alarm

Serviceability

Serviceability

- Access through the side engine cover and access panel:
 - Air cleaner
 - Fuel filter
 - Engine oil filter
 - Engine oil dipstick
 - Starter
 - Alternator
- Access within the cab:
 - Glass washer fluid
 - Fuses, diodes and relays
 - ISL control box

Miljö

Operator noise level (LpA) (EN 12053)	75 dB(A)
Level of acoustic power (LwA)	104 dB(A)
Helkroppsvibration (EN 13059)	1.30 ms ⁻²

BE OM **EN OFFERT**

Klicka bara på **knappen** eller skanna **QR-koden** nedan för åtkomst till vårt offertformulär.

Vi kontaktar dig så snart som möjligt. Tack!



BEGÄR OFFERT

