

Description

Packs soil after power, water lines or other shallow trenches have been installed in a yard, golf course, park, etc. Works efficiently in trenches 20 to 40 cm wide and up to 75 cm deep. Isolated vibratory shaker box is designed for long, trouble-free operation.

Dimensions

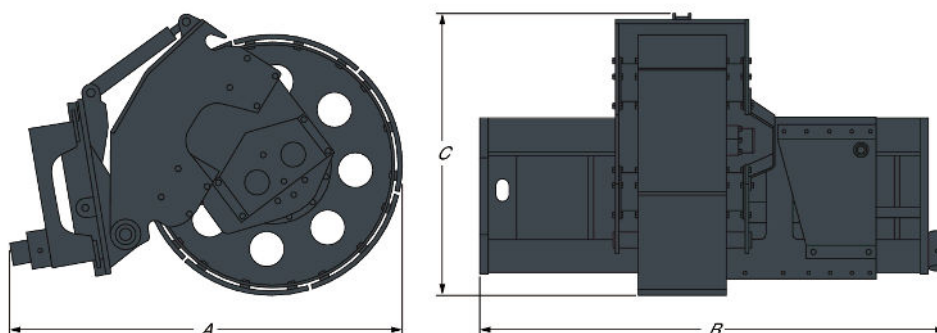

Description	Item number	Overall length (A) (mm)	Overall width (B) (mm)	Overall height (C) (mm)
Trench Compactor TC75	6726832	1448.0	1219.0	1499.0

Weights

Description	Item number	Operating weight (kg)	Shipping weight (kg)
Trench Compactor TC75	6726832	880.0	880.0

Characteristics and Performance

Description	Item number	Max working depth (mm)	Working width (mm)	Wheel diameter (mm)	Max side shift (mm)	Average working speed (m/min)	Required hydraulic flow (L/min)	Max vertical force (kg)	Vibration frequency (Hz)	Max inclination (°)
Trench Compactor TC75	6726832	0.0-750.0	200.0-400.0	1060.0	1100.0	5.0-50.0	45.0-60.0	42.0	30.0-40.0	18.0

Main features

- For the rapid and even tamping of the backfilling material in trenches.
- Extremely economic, ensuring a finished job that requires no further intervention.
- Possibility of operating with the machine at the side of the trench.
- Double vibratory counter-rotating shaft, situated at the centre of the wheel to guarantee considerable vertical tamping force and the elimination of horizontal vibration.
- Achievement of a solid base preventing further settlement in time, guaranteeing utmost safety for traffic.
- Adjustable wheel width thanks to the easy and rapid replacement of the external sections.

Applications

- Construction and Demolition
- Road work, Recycling and Cleaning

Loader Compatibility

Description	Item number	Compatible with loader	Functional requirements
Trench Compactor TC75	6726832	A770-B, T590E IIIB, T590B iT4, T650E iT4, T650B iT4, T770E IV, T770E T3, T770B T3, T870E IV, T870B T3, S510E IIIA, S510B, S530E IIIA, S530B, S550E IIIB, S550B iT4, S570B iT4, S590E IIIB, S590B iT4, S630E iT4, S630B iT4, S770E IV, S770E T3, S770B T3, S850E IV, S850E T3, S850B T3, A770E IV, S510E V, S530E V, T590E V, S66, S76, T66, T76, S510B, S530B, S550E V, S590E V, S630B iT4, S650B iT4	-

Accessories For Loader-Compatible Attachments

Description	Item number	Compatible with attachment	Functional requirements
Pads 8in/20cm for Trench Compactor	6726841	6726832 Trench Compactor TC1	-
Pads 10in/25cm for Trench Compactor	6726842	6726832 Trench Compactor TC1	-
Pads 12in/30cm for Trench Compactor	6726843	6726832 Trench Compactor TC1	-
Pads 14in/35cm for Trench Compactor	6726844	6726832 Trench Compactor TC1	-
Pads 16in/40cm for Trench Compactor	6726845	6726832 Trench Compactor TC1	-

BE OM **EN OFFERT**

Klicka bara på **knappen** eller skanna **QR-koden** nedan för åtkomst till vårt offertformulär.

Vi kontaktar dig så snart som möjligt. Tack!



BEGÄR OFFERT

