

Dimensions

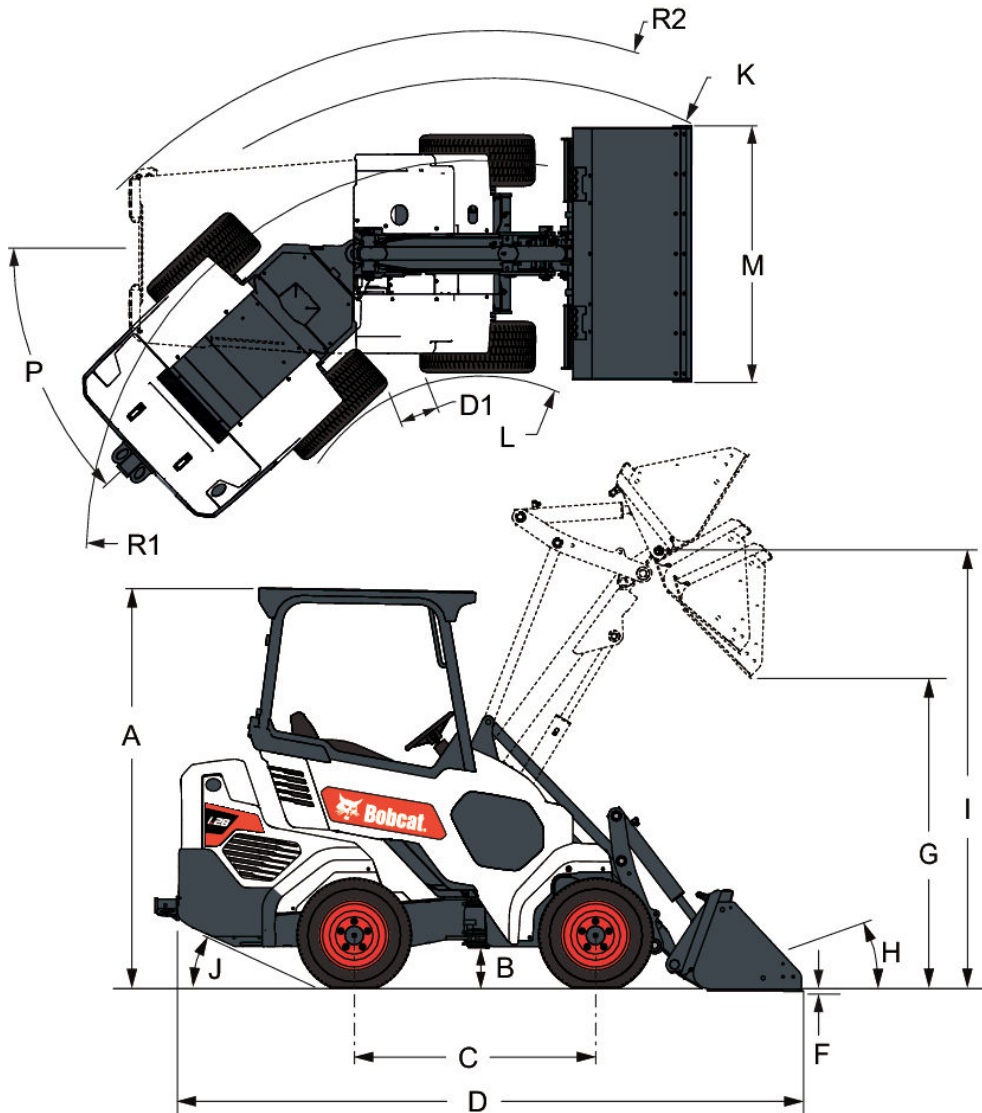

(A) Cab Height	1983.7 mm
(B) Ground Clearance	196.0 mm
(C) Wheelbase	1200.0 mm
(D) Overall Length with Bucket	3109.0 mm
(F) Dig Depth	19.5 mm
(G) Maximum Dump Height	2136.4 mm
(H) Load Over Height	30.0°
(I) Hinge Pin at Maximum Height	3107.1 mm
(J) Departure Angle	23.0°
(K) Turning Radius Over Bucket	2407.7 mm
(L) Turning Radius Inside Tire	931.5 mm
(M) Width Over Bucket	1270.0 mm
(O) Machine Width	1180.7 mm
(P) Articulation Angle	43.0°
(Q) Dump Angle at Maximum Height	40.0°

Performance

Tipping load - Straight - Bucket	1392 kg
Tipping load - Straight - Forks	945 kg
Tipping load - Straight - Extended - Bucket	805 kg
Tipping load - Straight - Extended - Forks	601 kg
Tipping load - Articulated - Bucket	1109 kg
Tipping load - Articulated - Forks	759 kg
Tipping load - Articulated - Extended - Bucket	645 kg
Tipping load - Articulated - Extended - Forks	479 kg
Rated Operating Capacity - Straight - Bucket	696 kg
Rated Operating Capacity - Straight - Forks	473 kg
Rated Operating Capacity - Straight - Extended - Bucket	403 kg
Rated Operating Capacity - Straight - Extended - Forks	301 kg
Rated Operating Capacity - Articulated - Bucket	554 kg
Rated Operating Capacity - Articulated - Forks	380 kg
Rated Operating Capacity - Articulated - Extended - Bucket	323 kg
Rated Operating Capacity - Articulated - Extended - Forks	239 kg
Lift Capacity	1085 kg
Breakout Force - Boom	1141 kg

Engine

Make / Model	KUBOTA / D1305-E4B-BC-1
Fuel	DIESEL
Cooling	53% PROPYLENE GLYCOL / 47% WATER MIXTURE
Power at 2600 RPM (ISO 14396)	18.2 kW
Torque at 1700 RPM (ISO 14396)	81.3 Nm
Number of cylinders	3 IN-LINE
Displacement	1 cm ³

Weight

Operating weight	1903 kg
Shipping weight	1731 kg

Hydraulic System

System Relief	20.0 MPa
Implement Pump	ENGINE DRIVEN GEAR TYPE
Implement Pump Capacity	45.80 L/min
Main Filter	REPLACEABLE 16(c) ≥ 75 ISO 4572, SPIN ON WITH O-RING, 0.34 MPa [50 psi] BYPASS
Tank Breather Filter	NON-REPLACEABLE 10 MICRON, THREAD-ON CAP
Control Valve	MANUALLY OPERATED SERIES TYPE (LIFT & TILT FUNCTIONS) WITH FLOAT DETENT ON LIFT. E/H OPERATED PARALLEL TYPE (AUX & TELESCOPIC FUNCTIONS)
Hydraulic Fluid	PREMIUM GRADE, ANTI WEAR, MULTI VISCOSITY ISO VG46, PETROLEUM BASED

Fluid Capacities

Cooling System	5.70 L
Fuel tank	36.20 L
Engine Oil	3.80 L
Hydraulic and Hydrostatic System	20.80 L

Drive System

Transmission	4 Wheel Drive with automatic drive modes, Optional Traction assist function
--------------	---

Electrical

Alternator	90 A OPEN FRAME WITH INTERNAL REGULATOR
Battery	12 VOLT BCI GROUP 26; 540 AMPS COLD CRANKING CAPACITY AT 0 F (-18 C); 80 MINUTE RESERVE CAPACITY
Starter	12 V GEAR TYPE 2.0 kW [2.68 hp]
Ignition Switch	ACTIVATES STARTER AND INSTRUMENTATION

Cycle times

Raising time	2.6 s
Lowering time	2.2 s
Dump time	1.4 s
Rollback time	1.8 s

Environmental

Bystander Noise Level (ISO 6395)	99 dB(A)
Operator Position Noise (ISO 6396/4871)	85 dB(A)
Hand-Arm vibration (ISO 5349-1/2)	0.55 ms ⁻²
Whole body vibration (ISO 5349-1/2)	0.67 ms ⁻²

Standard Features

- Automatic Traction Modes - High and Turf Safe
- Auxiliary Hydraulics
- BICS System (Interlock)
- Backup Alarm
- Canopy
- Cup Holder
- Fixed Lift Arm
- Front and Rear Work Lights
- Horn
- Hydraulic Self Level (Bucket Positioning)
- Lift-Arm Support
- Spark Arrestor Muffler
- Static Vinyl Seat
- Tires 23 x 10.50-12 - Turf

Options

- Adjustable Suspension Seat
- Cab Enclosure with Heater

- Counterweights
- Fender kit
- Heated Seat
- Lift Kit
- Power Bob-Tach Attachment System
- Radio
- Rear Guard
- Rear Window
- Road Lights
- Rotating Flashing Beacon
- Sediment Bowl
- Tires 23 x 8.50-12 - Tractor
- Tires 23 x 8.50-12 - Turf
- Tires 26 x 12.00-12 - Tractor
- Tires 26 x 12.00-12 - Turf
- Traction Assist
- Turn Signals

GET **A QUOTE**

Simply click **the button** or scan **the QR code** below to access our quote request form.

We will contact you as soon as possible.
Thank you!



REQUEST QUOTE >